

## Specifications

# SMART Board® M685E interactive whiteboard

Model SBM685E

## Overview

Your SMART Board® M685E interactive whiteboard features a durable interactive surface, two damage-resistant pens and SMART's proprietary DVIT® (Digital Vision Touch) technology. The SBM685E model supports dual touch, dual write and intuitive gestures, such as toss, rotate and zoom, available with multitouch operating systems.

The SBM685E interactive whiteboard supports the Epson® PowerLite 585W for SMART projector.

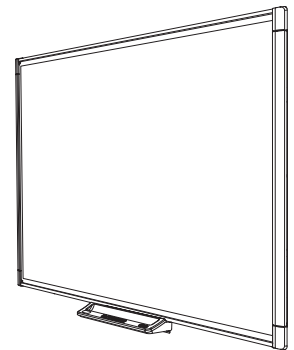

## Dimensions and weights<sup>1</sup>

### Dimensions

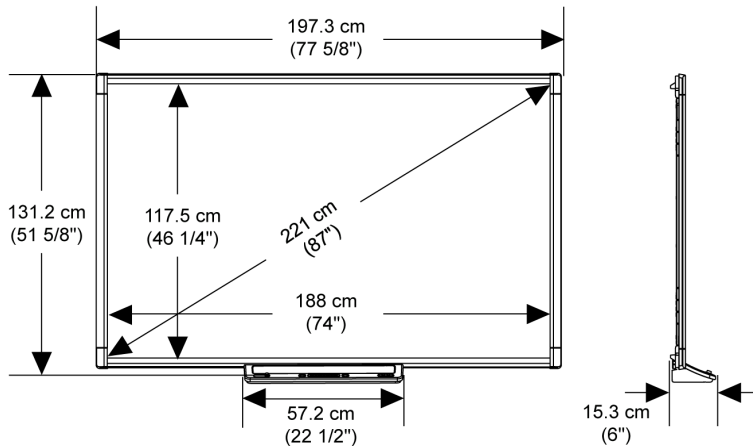

### Interactive whiteboard

#### Weight

51 lb. (23.1 kg)

#### Shipping dimensions

82" × 53" × 4 1/2"

(208.3 cm × 134.6 cm × 11.4 cm)

#### Shipping weight

69 lb. (31.3 kg)

### Accessory box

#### Shipping dimensions

33" × 4" × 7"

(83.8 cm × 10.2 cm × 17.8 cm)

#### Shipping weight

5 lb. 3 oz. (2.4 kg)

<sup>1</sup>All dimensions ± 1/8" (0.3 cm). All weights ± 2 lb. (0.9 kg).

## Standard features

<b>Software</b>	You can install SMART Product Drivers and SMART Notebook® collaborative learning software from the included DVD or from <a href="http://smarttech.com/downloads">smarttech.com/downloads</a> . Software upgrades are also available.
<b>Computer requirements</b>	A computer or laptop with a Windows® operating system or Mac operating system software and SMART Notebook software installed. For a complete list of computer requirements, go to <a href="http://smarttech.com/downloads">smarttech.com/downloads</a> and browse to the latest SMART Notebook release notes applicable to your operating system. <sup>2</sup>
<b>Touch and gestures</b>	You can write, erase and perform mouse functions by touching the interactive whiteboard with your finger or a pen. This interactive whiteboard also features gesture capability, providing a natural and flexible way to interact with content.
<b>Multitouch capabilities</b>	Support for two simultaneous touches enables up to two users to interact with the interactive whiteboard by using the included pens or other objects, or by using their fingers to write and to perform gestures.
<b>SMART Ink®</b>	Smooths out the appearance of the digital ink, improving the legibility of your handwriting. The ink becomes an object you can move and manipulate.
<b>Pen tray</b>	The pen tray connects to the interactive whiteboard and a projector. Use the color select buttons to change digital ink colors. Power and volume controls are available on the pen tray, as are the on-screen keyboard, right-click and orient features.
<b>Pen</b>	Includes two pens
<b>Screen surface</b>	The hard-coated steel surface is durable, is optimized for projection and is compatible with dry-erase markers.
<b>Digitizing technology</b>	Four-camera DVIT
<b>Frame finish</b>	White and light gray (approximates PANTONE® Cool Gray 4C)
<b>Power requirements</b>	6' (1.8 m) power cable and 6" (15 cm) Y cable. Power consumption is less than 7 W (100V to 240V AC, 50/60 Hz, 5V DC 2.0A)
<b>Computer connection</b>	Includes a 16' (5 m) USB 2.0 cable to connect to the room computer. Your SMART Board M685E interactive whiteboard supports one computer connection on a primary display only.

## Temperature specifications

<b>Storage</b>	-4°F to 122°F (-20°C to 50°C)
<b>Operation</b>	41°F to 95°F (5°C to 35°C) with up to 80% humidity, non-condensing

<sup>2</sup>A digital projector isn't included with this model of SMART Board interactive whiteboard. To take advantage of all interactive features, you must integrate a supported Epson digital projector.

## Certification and compliance

**Regulatory certification** CSA (U.S./Canada)

---

### Environmental compliance

China EIP

---

European Union REACH, RoHS, WEEE, Packaging and ErP Standby

---

U.S. Packaging and Conflict Minerals

## Warranty

**Interactive whiteboard** Two-year limited equipment warranty

---

**Accessories** The accessories have a one-year warranty.

## Purchasing information

### NOTE

A digital projector isn't included with this model of SMART Board interactive whiteboard. To take advantage of all interactive features, integrate a digital projector. The SMART Board M685E interactive whiteboard supports the Epson PowerLite 585W for SMART digital projector. This projector may or may not be available in your region. Contact your SMART reseller for more information.

---

### Order numbers

SBM685E 87" (221 cm) diagonal SMART Board M685E interactive whiteboard with an active pen tray. Includes a SMART Notebook software installation DVD.

---

**Optional accessories** See [smarttech.com/accessories](http://smarttech.com/accessories)

[smarttech.com/support](http://smarttech.com/support)  
[smarttech.com/contactsupport](http://smarttech.com/contactsupport)

© 2016–2019 SMART Technologies ULC. All rights reserved. SMART Board, SMART Notebook, SMART Ink, DViT, smarttech, the SMART logo and all SMART taglines are trademarks or registered trademarks of SMART Technologies ULC in the U.S. and/or other countries. Epson is a registered trademark of Seiko Epson Corporation. All other third-party product and company names may be trademarks of their respective owners. This product and/or use thereof is covered by one or more of the following U.S. patents: [www.smarttech.com/patents](http://www.smarttech.com/patents). Contents are subject to change without notice. 03/2019.